

--	--	--	--

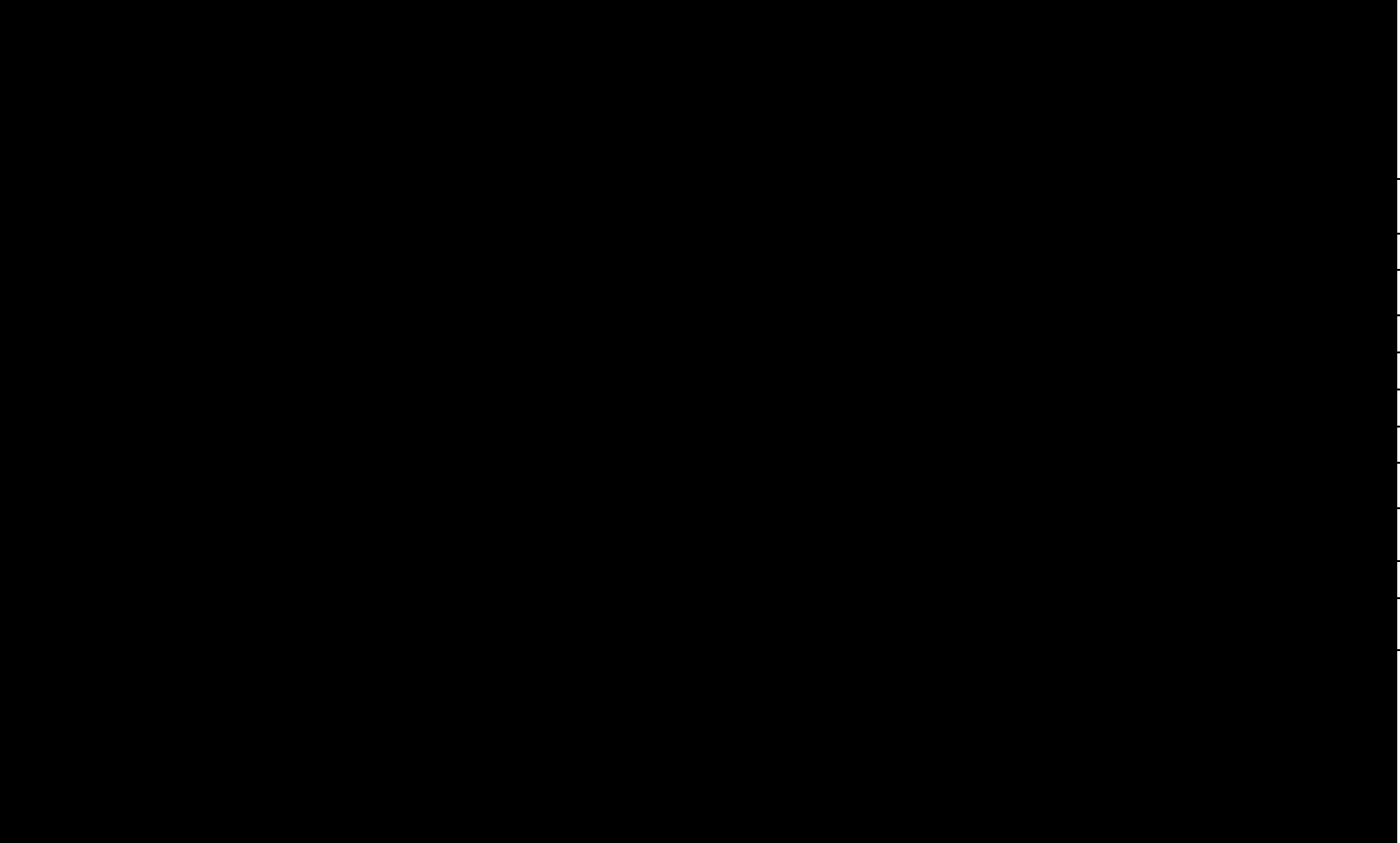

--	--	--	--

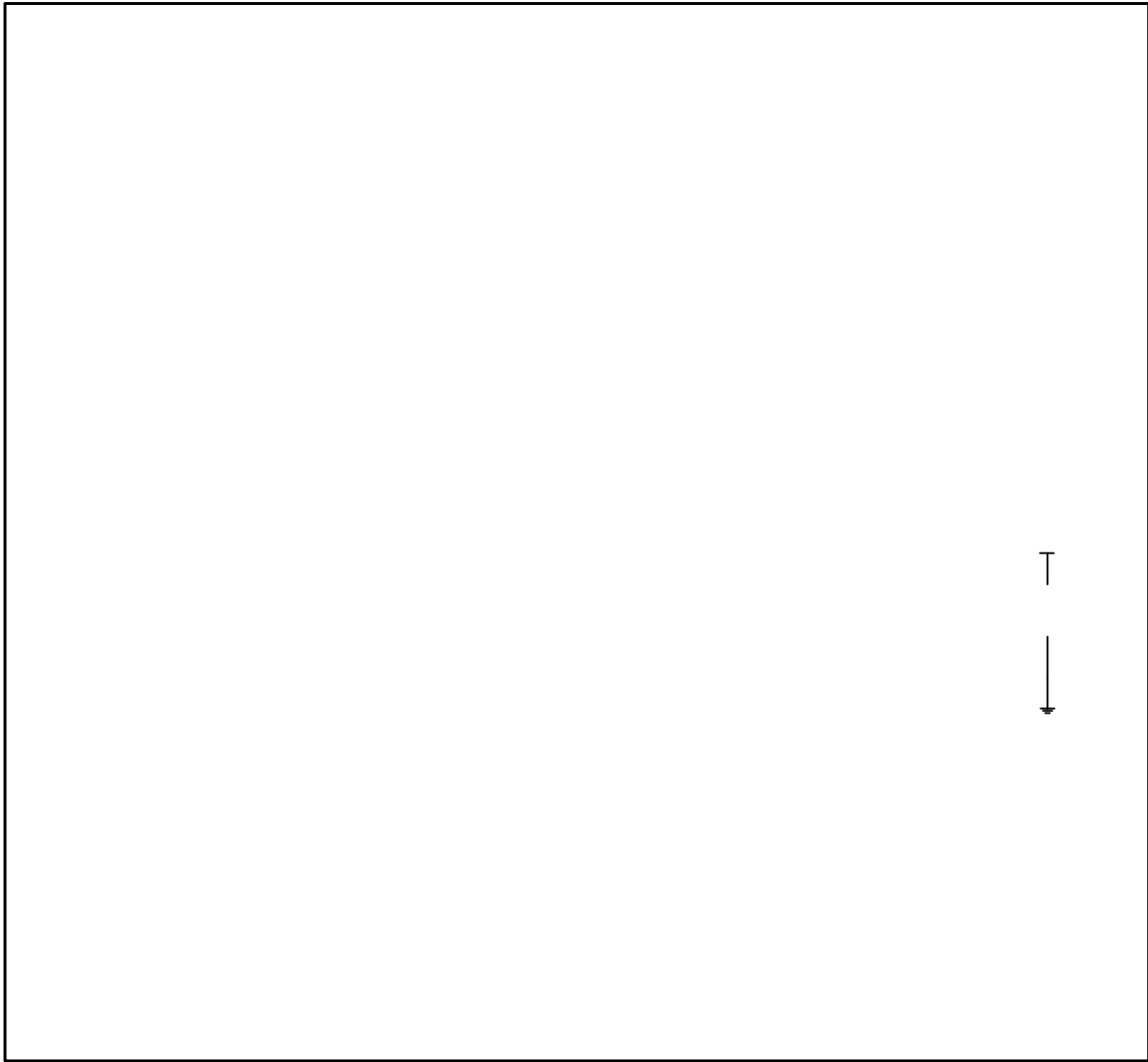



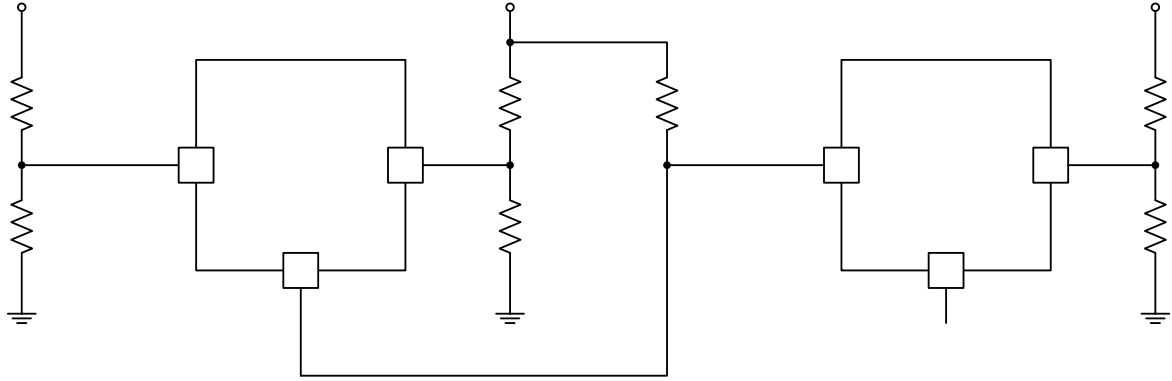

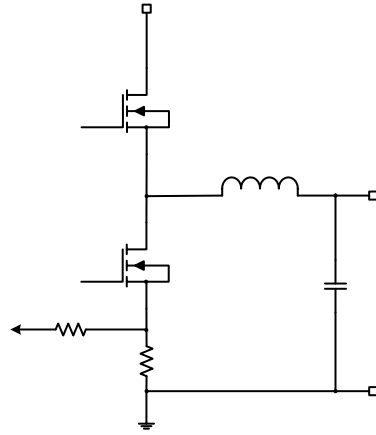
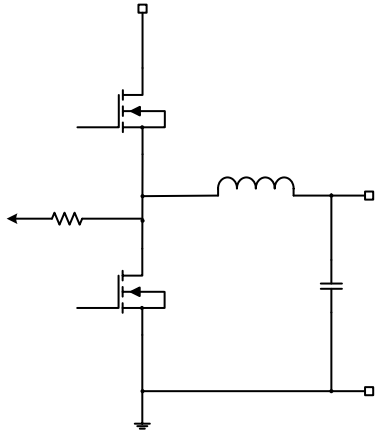

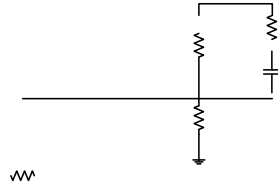

	<p style="text-align: center;">_____</p> <p style="text-align: center;">_____</p> <p style="text-align: center;">_____</p>
	<p style="text-align: center;">_____</p> <p style="text-align: center;">_____</p> <p style="text-align: center;">_____</p>
	<p style="text-align: center;">_____</p> <p style="text-align: center;">_____</p>

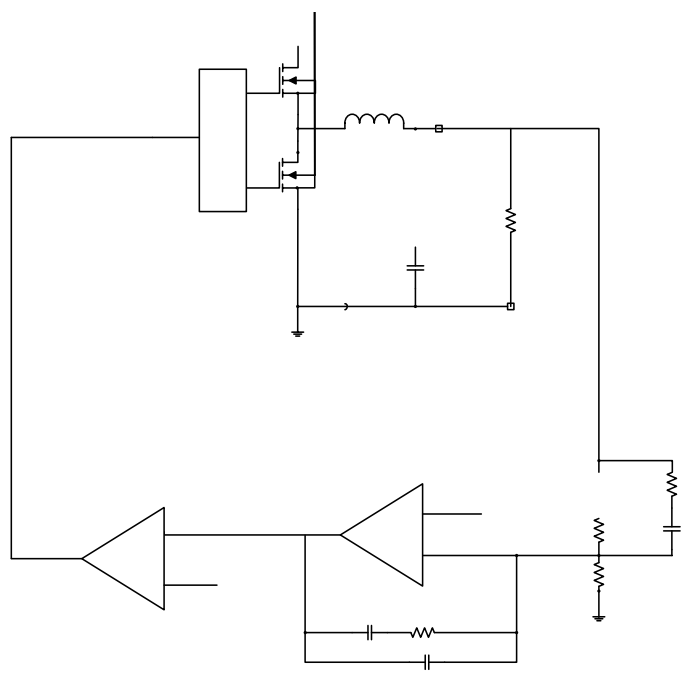

$\sqrt{\quad}$	\quad	\quad	\quad
		\quad	\quad



_____	_____
_____	_____

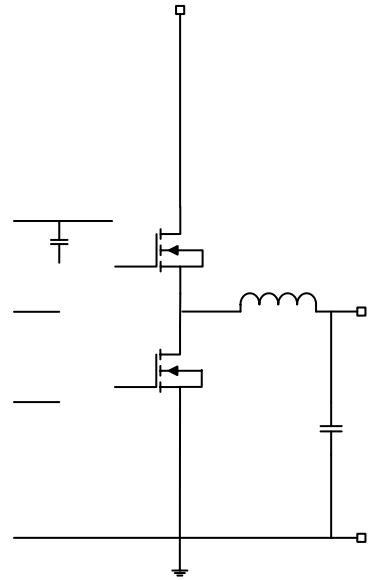

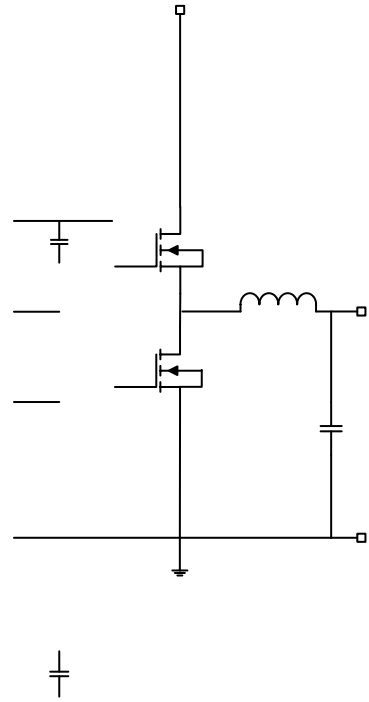

Vout	L	COU _T	R _{FB}	R _{FB}	R _c	C _c	C _c	R _c	C _c
V	. uH	* uF	. K	. K	. K	nF	pF		. nF
V	. uH	* uF	K	. K	K	. nF	pF		. nF
V	. uH	* uF	. K	. K	. K	. nF	pF		pF

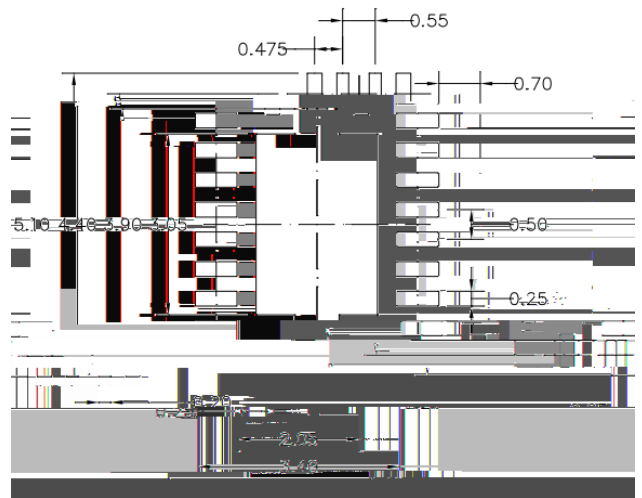
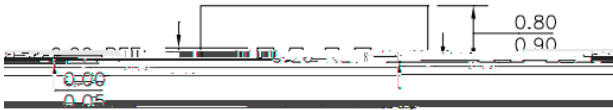
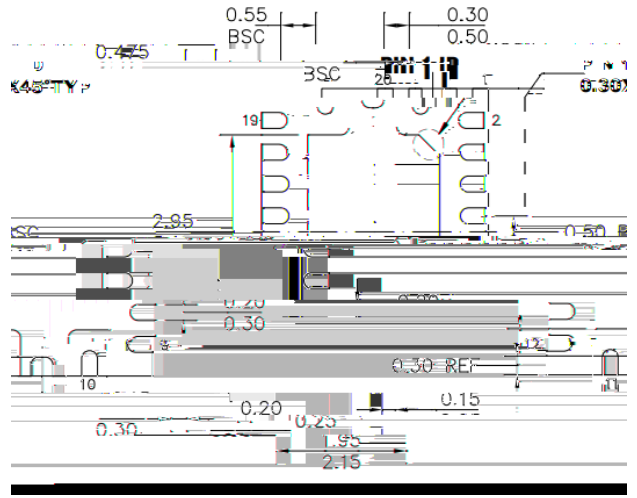
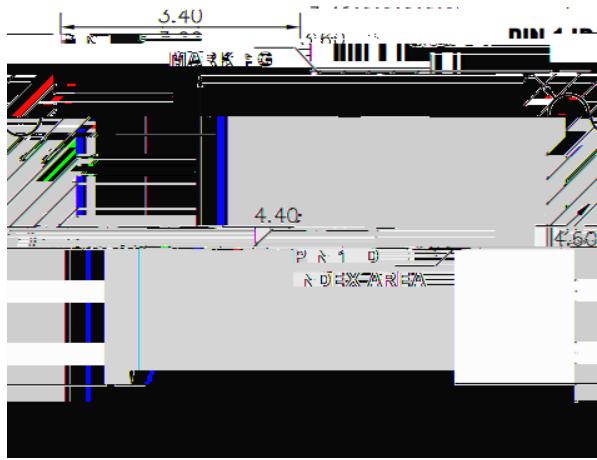



--	--	--	--	--	--

